

# HE ANIUM Wire Drawing and Annealing Guides

We maintain a large inventory of (OEM) parts for most wire manufacturing equipment. Each Heanium component is formulated to ensure optimum performance in high-temperature and corrosive environments. Additional standard and custom parts are available. Contact our **technical sales** department for more information.

Standard tolerances on all dimensions are  $\pm 0.010$  inch or  $\pm 1.5\%$ , whichever is greater. Diamond grind and/or hone to  $\pm 0.0005$  inches is available.

**USG-1**

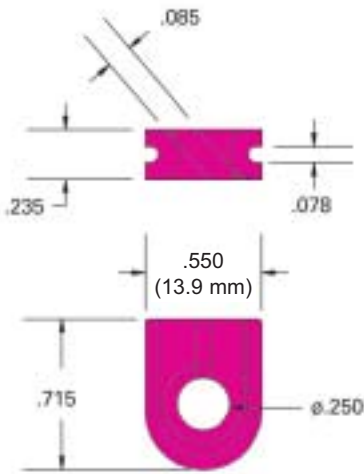

**USG-687-A**

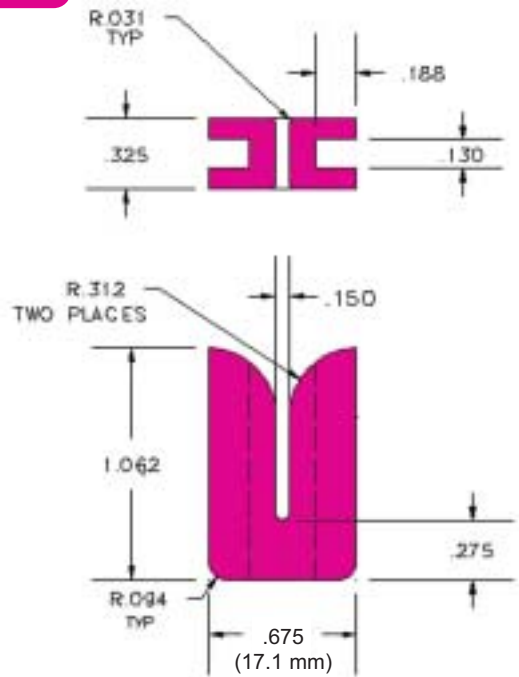

**UG1-0990-A**

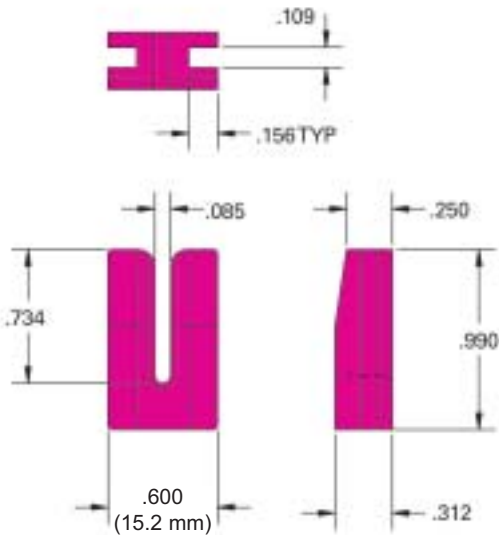

**A03153**

